

# TopScan

---

Bluetooth Vehicle Diagnostic Dongle | User Manual



**TOPDON**



# Contents

Safety Is Always the First Priority!	.....	4
Section 1 What's in the Box?	.....	5
Section 2 Product Overview	.....	6
Section 3 Getting Started	.....	8
Section 4 Using the TopScan via the App	.....	14
Section 5 Specifications	.....	48
Section 6 FAQ	.....	49
Section 7 Warranty	.....	50
Section 8 FCC	.....	51

## **Safety Is Always the First Priority!**

- For your safety, the safety of others, and to avoid any damage to the product and your vehicle, **CAREFULLY READ AND MAKE SURE YOU FULLY UNDERSTAND ALL THE SAFETY INSTRUCTIONS AND MESSAGES ON THIS MANUAL BEFORE OPERATING.** You must also read the vehicle's service manual, and observe the stated precautions or instructions before and during any test or service procedure.
- Keep yourself, your clothing and other objects away from moving or hot engine parts and avoid contact with electrical connections.
- **ONLY OPERATE THE VEHICLE IN A WELL-VENTILATED AREA,** as the vehicle produces carbon monoxide, a toxic and poisonous gas, and particulate matter when the engine is running.
- **ALWAYS WEAR APPROVED SAFETY GOGGLES** to prevent damage from sharp objects and caustic liquids.
- **DO NOT SMOKE OR HAVE ANY FLAMES NEAR THE VEHICLE** when testing. The fuel and battery vapors are highly flammable.
- **DO NOT ATTEMPT TO INTERACT WITH THE PRODUCT WHILE DRIVING.** Any distraction may cause an accident.
- **TURN THE IGNITION OFF BEFORE CONNECTING OR DISCONNECTING THE PRODUCT FROM THE DATA LINK CONNECTOR (DLC)** to prevent causing damage to the product or vehicle's electronic components.

# Section 1

## What's in the Box?

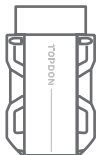

TopScan



Quick User Guide

# Section 2

## Product Overview

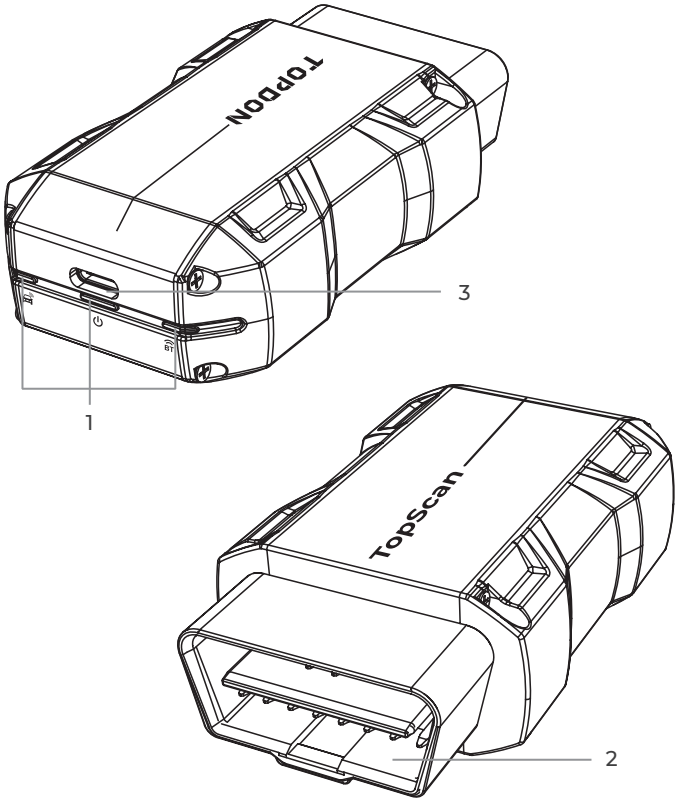

## 1. Indicators

---



Bluetooth Connection Indicator

Solid Blue: Bluetooth connected



Power Indicator

Solid Red: power on



Communication Indicator

Flashing Green: communicating with the vehicle

---

## 2. OBD-II 16 Pin Connector

Connects the TopScan to vehicle's DLC.

## 3. USB Type-C Port

The TopScan can be powered by an external power source using a USB cable (not included).

# Section 3

## Getting Started

### 3.1 Download the App

---

For iOS: Search for "TopGuru" in App Store to download and install.

For Android: Search for "TopScan" in Google Play to download and install.

**Note:**

*This app is compatible with iOS 11.0 or later / Android 7.0 or later.*



Figure 3-1



### 3.2 Register & Log In

---

Open the app and log in to your TOPDON account. (If you do not have an account, please register with your email.)

<

## TopScan

Sign in to your TOPDON Account

Please enter your email address

Please enter your password 

Remember Password [Forgot your password?](#)

Log In

Don't have an account? [Create Account](#)  
[Vehicle Coverage Lookup](#)

Figure 3-2

### 3.3 Bind the VCI

---

① Tap **Me > Device Management > Add VCI**.

② To get the serial number and activation code, please scan the QR code on the product.

Alternatively, tap the **VCI** icon at the top right of the activation screen to establish a Bluetooth connection (see Figure 3-3). Once the Bluetooth connection between the TopScan and your phone is established, the serial number and activation code will be automatically obtained.)

**Note:**

*The TopScan should be connected to a power source via its USB Type-C port or properly plugged into the vehicle's DLC before Bluetooth can be connected.*

③ Then, tap **Activate**.

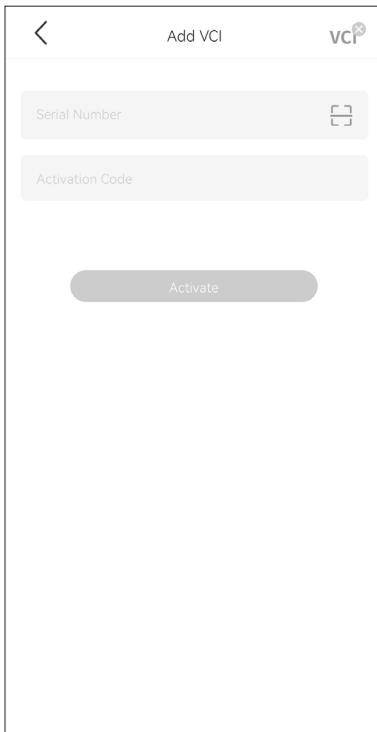

Figure 3-3

### 3.4 Download the Diagnostic Software

You will need to download the vehicle-specific software the first time you use the diagnostic function. Tap **Diagnostics** from the home screen and download the software you need.

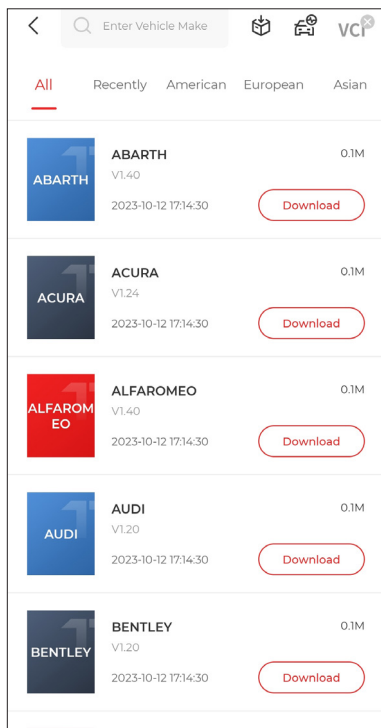

Figure 3-4

### 3.5 Plug the TopScan into the Vehicle's DLC

---

**Note:**

*Make sure the ignition is OFF before plugging in the unit.*

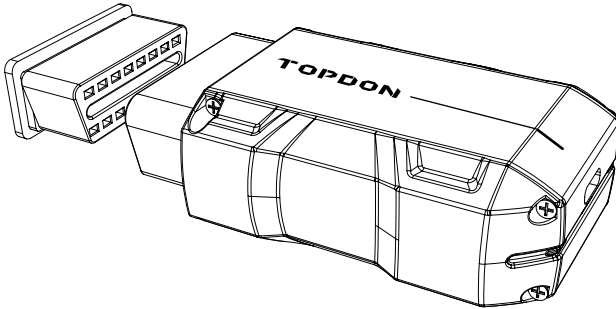

Figure 3-5

To locate the vehicle's DLC, tap **Repair Information >> DLC Location**, select vehicle make, model and year, and tap **Next**. A picture of DLC location for the selected vehicle will display.



Figure 3-6

### 3.6 Turn the Ignition to the "ON" Position (see Figure 3-7)

---

If your vehicle is equipped with a keyless start system and the ignition switch is an "Engine Start Stop" button (see Figure 3-8), press the "Engine Start Stop" button until the car is in "ON" mode. Do not apply the brake while pressing the "Engine Start Stop" button or you will start the car instead of putting it in the "ON" position.

The method of ignition varies by vehicle model. Refer to the vehicle's service manual for details.



Figure 3-7

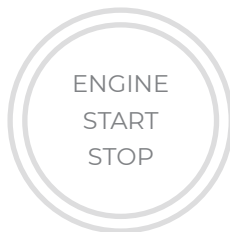

Figure 3-8

### 3.7 Bluetooth Connection

---

Tap the **VCI** icon at the top right of any screen with this icon to establish Bluetooth connection with the TopScan unit. After the connection is successfully established, the icon changes to **VCI** .

Once Bluetooth is successfully paired, the connection will be automatically established when you open the app. If not connected, manually tap the icon to reconnect.

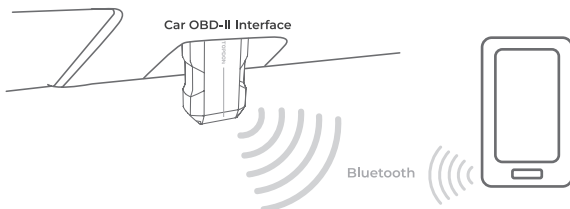

Figure 3-9

# Section 4

## Using the TopScan via the App

### 4.1 Home Screen

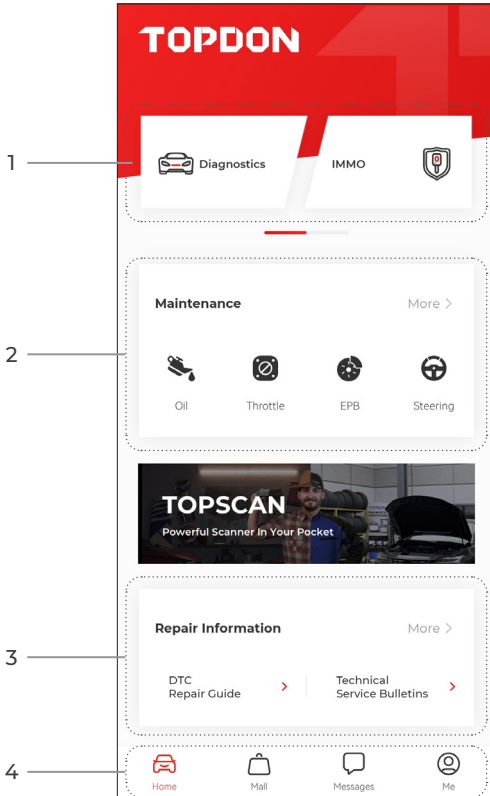

Figure 4-1

#### 1. Main Functions

Swipe right or left to move through the functions.



Diagnostics

Configures the TopScan to operate as a scan tool.



IMMO (Optional)

Configures the TopScan to operate as a key programming tool.



I/M Readiness

Provides quick access to check the status of the emission-related systems.



Vehicle Performance

Allows you to perform acceleration tests on your vehicle.



VE Calculator

Allows you to calculate Volumetric Efficiency (VE) to check the engine performance.



T-Darts

Configures the TopScan to operate as a transponder reader and remote frequency tester.

---

## 2. Maintenance Service Functions

Provides 8 maintenance service functions (for the advanced product version - TopScan Pro, there are 13 maintenance service functions available).

## 3. Repair Information

Includes DTC Repair Guide, Technical Service Bulletins, DLC Location and Warning Light Library, which provides reference information on vehicle inspection, diagnostics, and repair.

## 4. Toolbar

---



Home

Selecting this icon returns you to the home screen.



Mall

Allows you to purchase or renew diagnostic / IMMO software license.



Messages

Selecting this icon opens the message screen.



Me

Selecting this icon opens the Me screen, which allows you to view the account profile, saved data files, and FAQ, manage the installed software and connections to VCI / T-Darts, look up vehicle coverage, check for firmware updates, and access general settings.

---

## 4.2 Diagnostics

---

The Diagnostics module allows you to scan all supported vehicle systems at one time (Auto Scan) for Diagnostic Trouble Codes (DTCs) or select an individual system to perform Read Trouble Code, Clear Trouble Code, Read Data Stream, Read Version Information and Active Test. You can also access EOBD and Diagnostic Feedback through this module.

### 4.2.1 Auto Scan and Individual System Diagnostics

#### Identifying the Vehicle

To perform Auto Scan or Individual System Diagnostics, you need to identify your vehicle first.

1. Tap **Diagnostics** from the home screen. A list of vehicle-specific diagnostic software will display.



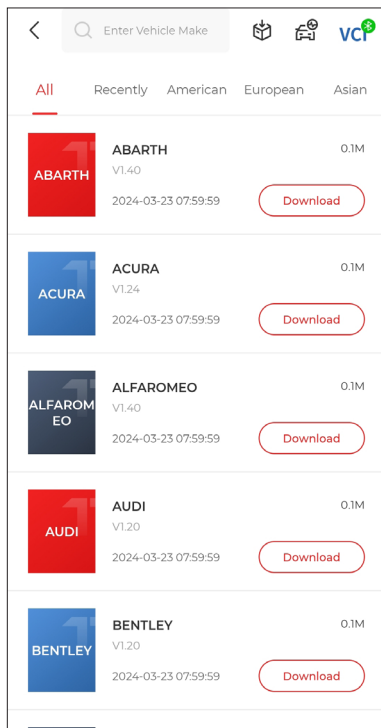

Figure 4-2

2. Select the software by your vehicle make (If you have not downloaded the software, please download and install the software first).

**Note:**

*A demonstration mode (**DEMO** option) is provided to help you become familiar with Diagnostics functions.*

3. Select **Automatic / Manual** to identify the vehicle.

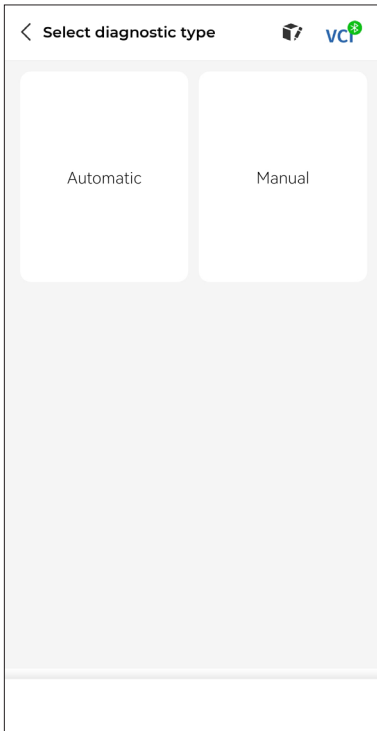

Figure 4-3

### **Automatic**

Manually enter Vehicle Identification Number (VIN) or tap **Read** to acquire VIN, then tap **Confirm**. TopScan will automatically decode the VIN to identify the vehicle.

### **Manual**

Manually select the vehicle information to identify the vehicle.

Alternatively, you can tap the  icon at the top right of the screen and select AutoVIN, Enter VIN or Scan VIN to identify the vehicle.

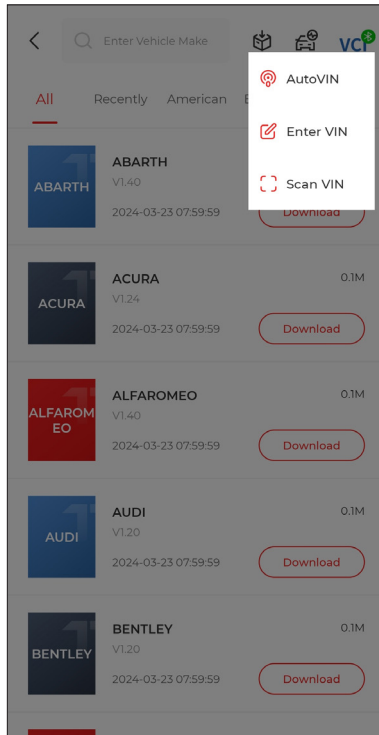

Figure 4-4

**AutoVIN** - The TopScan automatically reads and decodes the VIN.

**Enter VIN** - manually enter the VIN.

**Scan VIN** - tap to scan the VIN characters.

4. A systems menu will display after the vehicle is identified.

**Note:** *Systems may vary by vehicle make, model and year.*



Figure 4-5

You can either select **Auto Scan** or tap a vehicle system to open the function menu for that system.

## Auto Scan

Auto Scan detects the systems supported by the vehicle and retrieves DTCs for all of these systems, providing a complete health check of your vehicle. Performing Auto Scan before and after repair could help in troubleshooting and validating repairs. Pre and post scan reports can allow you to record the condition of the vehicle before and after repair for comparison.

To perform an Auto Scan, tap the **Auto Scan** button. The TopScan will start scanning all the systems supported by the vehicle, and DTC retrieval will be automatically proceeded.

Results are displayed progressively as the systems are scanned.

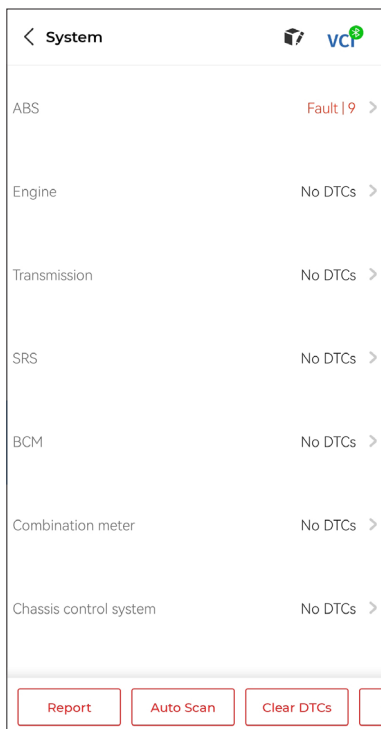

Figure 4-6

## Button Description

**Report** - tap to save the current scan results in report format. (To view the saved reports, go to **Me > Diagnostic Report.**)

**Clear DTCs** - tap to clear all the DTCs retrieved.

**Show All / Show Actual** - tap to toggle between showing all vehicle systems and showing only the supported systems.

## Performing Individual System Diagnostics

To access the function menu of a certain system:

From the systems menu, select the desired vehicle system. Available function options for the system will be displayed. Select a function to continue.

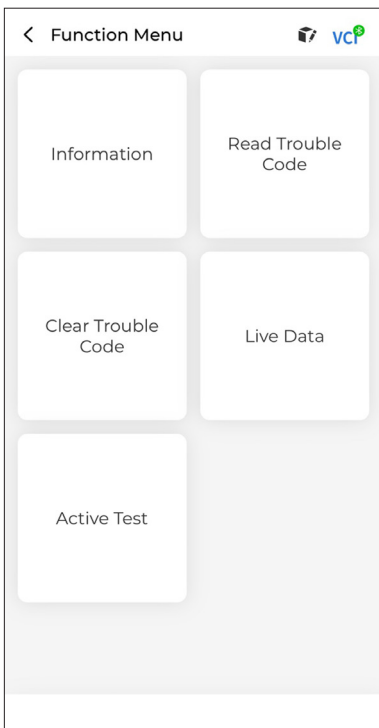

Figure 4-7

**Note:** Depending on the vehicle make, some functions may not be available.

## Read Version Information

Tap **Information** in the function menu. Then you can view the version information of the Electronic Control Unit (ECU) for the currently selected system.

## Read Trouble Code

To retrieve DTC for the currently selected system:

Tap **Read Trouble Code** in the function menu. TopScan will communicate with the ECU and retrieve and display DTCs for the currently selected system.

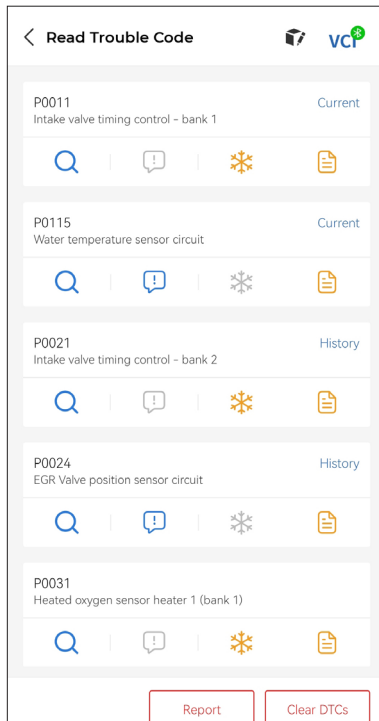

Figure 4-8

## Icon Description

---



Tap to open a window that allows you to search on Google for more information about the DTC.



When the icon lights up, tap to view the detailed description of the DTC.



When the icon lights up, tap to view the freeze frame captured at the time when the DTC occurs.



When the icon lights up, tap to view the instructional repair measures.

---

## Button Description

**Report** - tap to save the results in report format. (To view the saved reports, go to **Me > Diagnostic Report**.)

**Clear DTCs** - tap to clear all the DTCs retrieved.

### **Clear Trouble Code**

To clear DTCs for the currently selected system:

1. Tap **Clear Trouble Code** in the function menu.
2. Tap **OK** when the DTCs are cleared.

### **Note:**

*1. Procedure of clearing DTCs should be performed after the required repair has been carried out. Once confirmed, DTCs and freeze data stored in the ECU will be cleared.*

*2. DO NOT START UP THE ENGINE WHILE CLEARING DTCs.*



## Read Data Stream

To view data stream for the currently selected system:

1. Tap **Live Data** in the function menu.  
A data stream list displays.

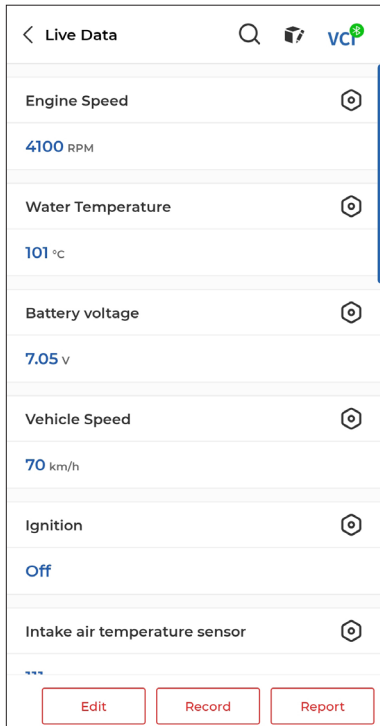



Figure 4-9

### Button Description

**Edit** - allows you to customize your data stream list. Select the check box of the data stream you are interested in viewing and tap **Confirm**.

**Record** - allows you to record and save data stream information for comparison and analysis. To view the saved data stream information, go to **Me > Data Stream**.

**Report** - tap to save the current data stream values in report format. To view the saved reports, go to **Me > Diagnostic Report**.

Each entry of the list shows the name and the current value of the data stream. You can tap the  icon at the side of each entry to enter the setting screen. The data stream can be viewed in value, graph, or gauge format (see Figure 4-10).

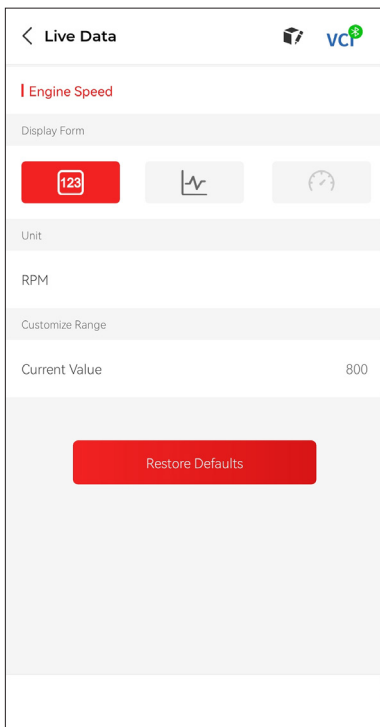



Figure 4-10

2. For ease of comparison and observation, the Combine function is provided which allows up to 4 data streams to be viewed in one graph.

To access the Combine function:

① Tap the icon  to change the display form, and go back to the data stream screen.

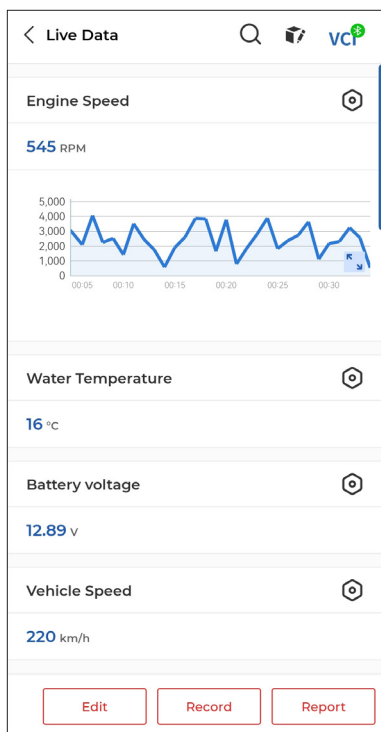

Figure 4-11

② Tap the full screen icon  at the right side. The following screen will appear.

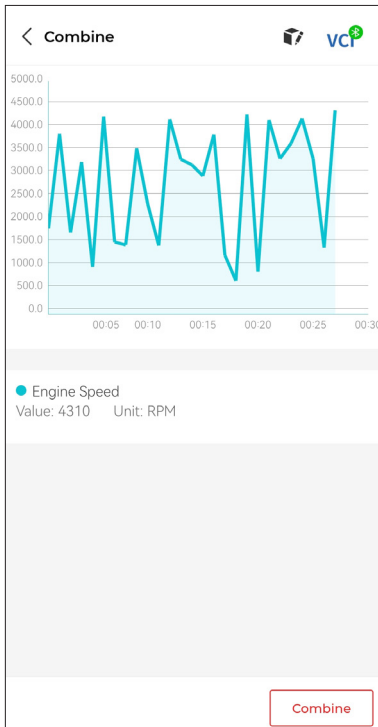



Figure 4-12

③ Tap **Combine**, and select up to four data streams.

< Select Data Stream 

Tips: Up to four data streams can be combined.

- 1 Engine Speed
- 2 Water Temperature
- 3 Battery voltage
- 4 Vehicle Speed
- 5 Ignition
- 6 Intake air temperature sensor
- 7 Exhaust gas recirculation temperature sensor
- 8 Park / neutral position switch
- 9 Power steering signal

Confirm(4)

Figure 4-13

④ Tap **Confirm**. A combined graph will display.

**Note:**

*IF THE VEHICLE MUST BE DRIVEN TO VIEW THE LIVE DATA STREAM, ALWAYS HAVE A SECOND PERSON HELPING YOU. DO NOT WATCH THE DATA STREAM WHILE DRIVING.*

## Active Test

- allows you to manually control certain component operations directly from the app to verify the operations of components.

### **Note:**

*Available tests vary by vehicle make, year and model.*

## 4.2.2 EOBD

The EOBD function allows you to perform emission-related diagnostics for your vehicle.

To perform EOBD Diagnostics:

1. Tap **Diagnostics** from the home screen. Select **EOBD** in the displayed vehicle make list.
2. Select your communication method: **Auto Scan** or **Protocol**.

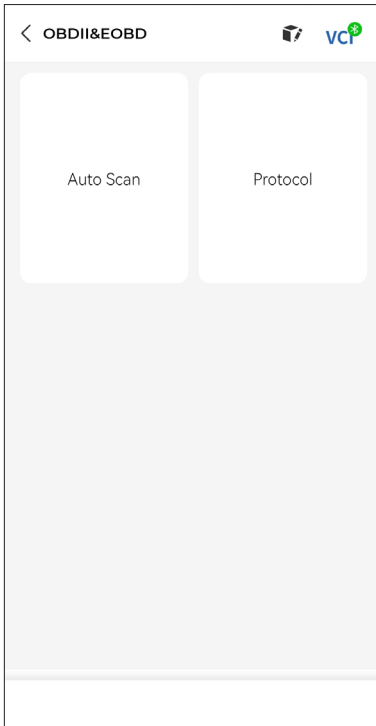

Figure 4-14

**Auto Scan** - The TopScan will automatically communicate with the vehicle and identify which protocol the vehicle is using.

**Protocol** - allows you to manually select the communication protocol.

After the communication protocol is confirmed, a vehicle status screen displays showing the protocol and other status info of your vehicle.



Description	Value
MIL status	Off
Codes found	0
Monitors N/A	5
Monitors OK	3
Monitors INC	3
Protocol	ISO 14230- 4 (KWP 2000)

OK

Figure 4-15

3. Tap **OK** to enter the function menu.

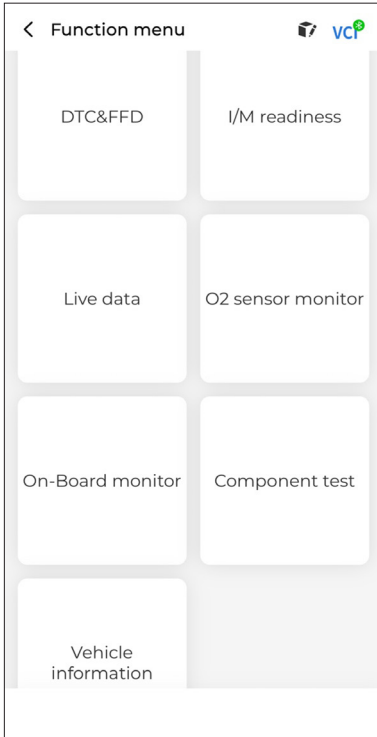

Figure 4-16

4. Select a function to continue.

**Note:** Depending on the vehicle make, some functions may not be available.

Typical function options may include:

- DTC & Freeze Frame Data
- I/M Readiness
- Live Data
- O2 Sensor Monitoring
- On-Board Monitoring
- Component Testing
- Vehicle Information



## **DTC & FFD (Freeze Frame Data)**

This function helps retrieve and clear DTCs stored in the vehicle's ECU and displays FFD of the emission-related systems.

### **1. Read DTCs**

This function displays the DTCs retrieved from the emission-related systems.

### **2. Clear DTCs**

This function allows you to clear the DTCs retrieved from the emission-related systems.

### **3. FFD**

This function takes a snapshot of the data and operating conditions when an emission-related fault occurs.

#### **Note:**

- 1. The procedure of clearing DTCs should be performed after the required repair has been carried out. Once confirmed, DTCs and FFD stored in the ECU will be cleared.*
- 2. DO NOT START UP THE ENGINE WHILE CLEARING DTCs.*

## **I/M (Inspection and Maintenance) Readiness**

This function checks whether or not the various emission-related systems on the vehicle are operating properly, and are ready for I/M testing.

It can also be used to check the monitor running status and to confirm if the repair of a car fault has been performed correctly.

### **Live Data**

This function displays the real-time live data and parameters from the vehicle's ECU.

### **O2 Sensor Monitor**

This function displays O2 sensor monitor test results of the most recently completed tests from the vehicle's ECU.

### **On-Board Monitor**

This function displays the test results for emission-related powertrain components and systems that are not continuously monitored.

### Component Test

This function helps send control commands to the vehicle's ECU as a way to test and operate the system parts and components.

### Vehicle Information

This function displays a list of information (provided by the vehicle manufacturer) from the vehicle's ECU.

The information may include:

- VIN
- Calibration ID (CID)
- Calibration Verification Number (CVN)

### 4.2.3 Diagnostic Feedback

The TopScan allows you to instantly send diagnostic feedback (with logs of diagnostic data automatically attached) while you are encountering a software problem with the diagnostics operations. To send diagnostic feedback:

1. Tap the  icon located at the top right corner of any screen in the Diagnostics module.
2. Select the type of problem.
3. Write a description of the problem.
4. Tap **Submit** to send the feedback.

### 4.3 IMMO (Immobilizer)

---

IMMO is an optional function allows you to perform IMMO related functions such as Number of Keys, Read Pin Code, Remote Control Learning, Add Key, Erase Key and All Key Lost.

**Note:**

To access the IMMO functions, you need to purchase IMMO software license (tap **Mall** in the toolbar of the home screen to order). For the advanced product version - TopScan Pro, the IMMO function is included for free for one year.

To perform the IMMO functions:

Tap **IMMO** from the home screen. Download the IMMO software according to your vehicle make. Then identify your vehicle to get access to the function menu. Select a function to continue. Follow the on-screen instructions to perform the procedures.

**Note:**

Available functions may vary by vehicle make, year and model.

### 4.4 I/M Readiness

---

This function checks whether or not the various emission-related systems on the vehicle are operating properly, and are ready for I/M testing.

It can also be used to check the monitor running status and to confirm if the repair of a car fault has been performed correctly.

**Note:**

The vehicle should only be considered ready for inspection and allowed to pass emissions if all required tests have been passed.

### 4.5 Vehicle Performance Test

---

Vehicle Performance Test allows you to make accurate measurements of vehicle acceleration, providing results at intervals defined by set speed and fixed distance measurements.

## 4.5.1 Performing a Vehicle Performance Test

1. Tap **Vehicle Performance** from the home screen.
2. A warning message appears. Carefully read the message and tap **OK** to continue.

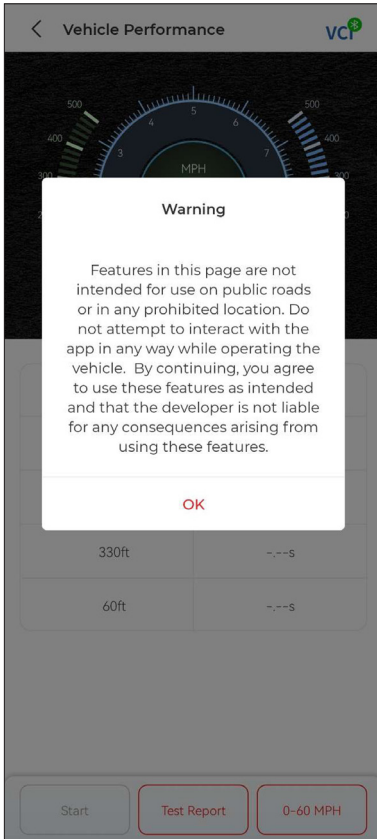

Figure 4-17

3. The default values for the start and end speeds are 0 MPH and 60 MPH respectively. If you want to change the values, tap the **0-60 MPH** button, and tap **Edit** to set the start and end speeds.

4. Accelerate your vehicle to start the test.

**Note:**

*If you do not reach the end-of-measurement speed, the results will be automatically reset as soon as the speed of the car is equal to the start speed.*

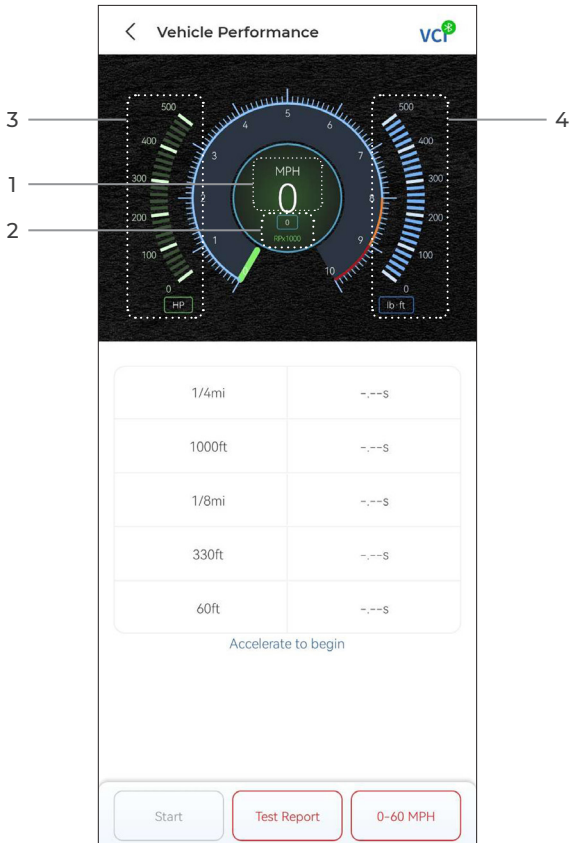

Figure 4-18

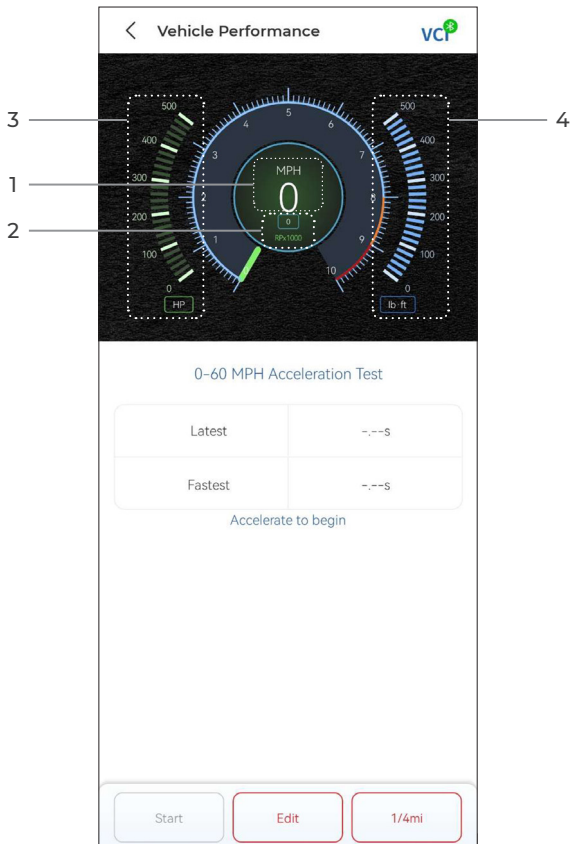

Figure 4-19

- ① Vehicle Speed
- ② Engine Speed
- ③ Horsepower
- ④ Torque

### Button Description

**Start** - tap to reset for the next run

**Test Report** - tap to view the test results

**0-60 MPH / (1/4 mi)** - tap to toggle between 0-60 MPH result screen

and 1/4 mi result screen.

**Edit** - tap to set the start and end speeds.

#### 4.5.2 Viewing Test Results

1. From the test screen, tap **Test Report**. The result screen will appear.

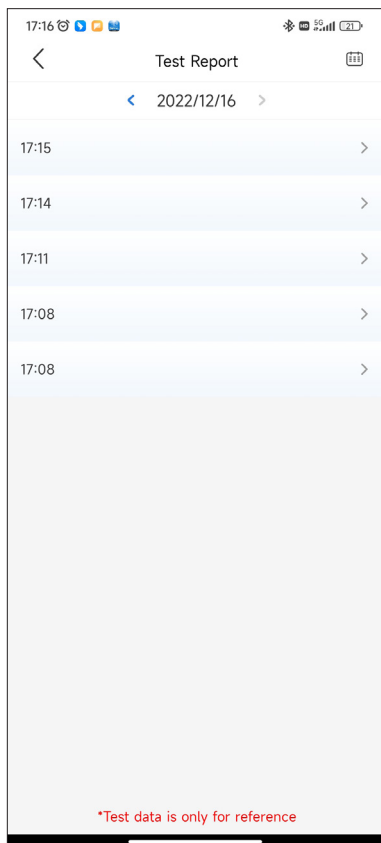

Figure 4-20

2. Tap the desired record to view its full content.

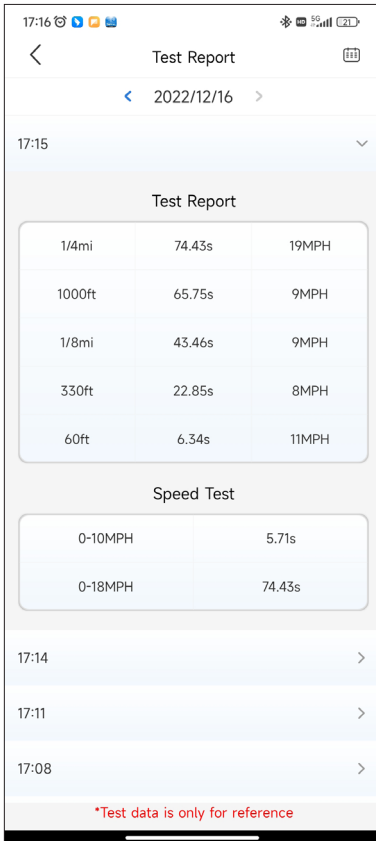

Figure 4-21

**1/4 mi Test Results** - record the elapsed time for a vehicle to travel a certain distance (60 ft, 330 ft, 1/8 mi, 1000 ft, 1/4 mi), and the instantaneous speed at each point (see Figure 4-18 and Figure 4-21).

**0-60 MPH Test Results** - record the elapsed time for a vehicle to accelerate from 0 to 60 miles per hour (see Figure 4-19). The values for the start and end speeds can be changed if desired.

**Speed Test Results** - record the elapsed time for a vehicle to accelerate to a specific speed (see Figure 4-21).



## 4.6 VE Calculator

---

The VE Calculator allows you to calculate the volumetric efficiency of your vehicle engine, which is one of an important engine performance parameters.

To calculator the VE:

Tap **VE Calculator** from the home screen, enter the required values including Engine Size, Engine Speed, MAF, Intake Air Temp, Number of Cylinders, and Air Intake Pressure. Then, tap **Calculate**.

## 4.7 T-Darts

---

The T-Darts function is used to read transponder information, test remote control frequency and test IMMO / PKE coil. To access the T-Darts function, additional hardware (sold separately) is required. To purchase the T-Darts unit, contact your local dealer.

## 4.8 Maintenance

---

The TopScan supports 8 special functions, including Oil Reset, Throttle Adaptation, Electronic Parking Brake (EPB) Reset, Steering Angle Reset, Diesel Particulate Filter (DPF) Regeneration, Anti-lock Braking System (ABS) Bleeding, Battery Management System (BMS) Resets, and Airbag Reset.

For the advanced TopScan Pro version, there are 5 additional special functions available, which include Injector Coding, Tire Pressure Monitoring System (TPMS) Reset , Sunroof Initialization, Seat Calibration, and Window Calibration.

### 4.8.1 Services Overview

#### Oil Reset

This function allows you to reset the oil service lamp for the engine oil life system, which calculates an optimal oil life change interval depending on the vehicle driving conditions and weather events. Oil reset is required every time the engine oil is changed.

#### EPB Reset

This function helps you replace and reset the brake pads.

It needs to be performed in the following cases:

- After the brake pads and brake pad wear sensor are replaced;
- When the brake pad warning light is on;
- After a short circuit in the brake pad sensor is fixed;
- After the servo motor is replaced.

### **Steering Angle Reset**

If the steering angle sensor is replaced, or the steering angle is inaccurate or not centered, the steering angle reset function needs to be performed to find the relative zero position. With this position as a reference, the ECU can then calculate the exact angle for left and right steering.

### **BMS Reset**

After the car battery is replaced, the car battery control unit needs to be reset. This will clear fault information (such as low battery level) so that the control unit can match the relevant information of the newly replaced battery.

### **ABS Bleeding**

When the brake system is opened to replace components such as brake pump, master cylinder, brake lines or brake fluid, air gets inside, which can lead to a soft brake pedal. ABS Bleeding is required to restore the firmness of the brake pedal.

### **Throttle Adaptation**

If the ECU is disconnected accidentally, or if the throttle is replaced or cleaned, then the throttle actuators need to be initialized via the Throttle Adaptation function. This resets the ECU's data to its initial state so that the throttle can accurately regulate the air intake.

### **DPF Regeneration**

This function is mainly used for the regeneration of diesel particulate filters. To keep the filters performing well it removes particles by means of combustion and oxidation.

### **Airbag Reset**

This function allows you to reset the airbag data to turn off the airbag light, so that the airbag control module can run normally.

It needs to be performed in the following cases:

- When the airbag deploys;
- When the diagnostic tool reads "Crash data stored";
- When the airbag light is on;
- When relevant DTCs cannot be cleared.

### **Injector Coding**

After replacing injectors, various codes need to be written to correspond to the code of each cylinder injector. This controls the quantity of oil injection into each cylinder.

### **TPMS Reset**

After the tire has been reinflated or replaced, the tire pressure

information needs to be reset via the tire pressure reset function to resolve the tire pressure fault code.

### **Sunroof Initialization**

This function is used to initialize the sunroof control module data, set the sunroof lock switch, close the sunroof in case of rain, check memory function for sliding/tilting sunroofs, gauge outside temperature threshold, etc.

### **Seat Calibration**

Seat Calibration is necessary when a vehicle's seat, which has memory functions, is replaced or repaired.

### **Window Calibration**

When a vehicle's battery is disconnected or low on power, or after the window motor has been replaced, the automatic up and down functions of the electronic window regulator may fail. If this occurs, Window Calibration is necessary to initialize the vehicle doors and windows for normal operation.

## 4.8.2 Performing a Service Reset

1. Tap **Maintenance** from the home screen. A function menu will display.

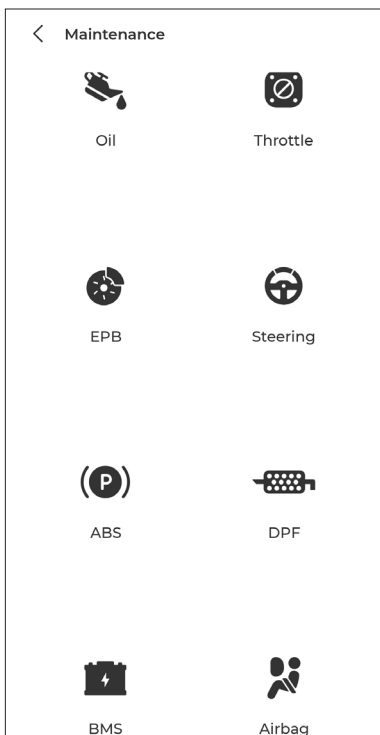

Figure 4-22

2. Select a function that you want to perform.

3. Vehicle identification is required before you can access the function (for more on identification operations, refer to **Identifying the Vehicle** on page 16). When it completes, the function menu displays.

4. Follow the on-screen instructions to perform the service reset.

## 4.9 Repair Information

---

### 4.9.1 DTC Repair Guide

The DTC Repair Guide is an experience-based database of generic OBD-II DTCs, which provides code-specific information, including popular fixes and repair steps for identifying faults.

To use the DTC Repair Guide:

Tap **Repair Information > DTC Repair Guide**. Enter a DTC in the search bar to search.

### 4.9.2 Technical Service Bulletins

To view technical service bulletins:

Tap **Repair Information > Technical Service Bulletins**. Select vehicle make, model, year, system and subsystem, and tap **Next**. A list of OEM technical service bulletins issued for the selected vehicle will display. Tap the desired option to view the full content.

### 4.9.3 DLC Location

To view DLC location:

Tap **Repair Information > DLC Location**. Select vehicle make, model and year, and tap **Next**. A picture of the DLC location for the selected vehicle will display.

### 4.9.4 Warning Light Library

The Warning Light Library provides information on dashboard warning lights, including light descriptions, impacts on driving, typical causes, responsive measures and relevant FAQs.

To use the Warning Light Library:

Tap **Repair Information > Warning Light Library**. A list of warning lights will display. Tap the desired option to view the details.

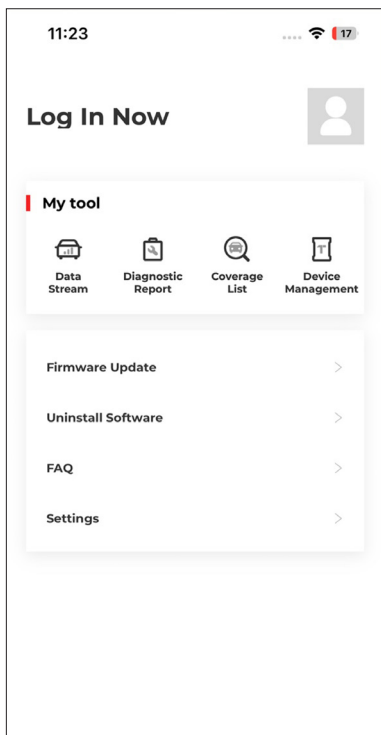

Figure 4-23

### 4.10.1 Account Profile

You can tap the profile photo to view and edit the profile information.

### 4.10.2 Data Stream

Allows you to view the saved data stream information.

### 4.10.3 Diagnostic Report

Allows you to view the saved diagnostic reports.

#### **4.10.4 Vehicle Coverage Lookup**

Allows you to check whether the TopScan is applicable to your vehicle.

#### **4.10.5 Device Management**

Allows you to bind the VCI / T-Darts (sold separately) to your account.

#### **4.10.6 Firmware Update**

Allows you to update the VCI firmware if a new version is available.

#### **4.10.7 Uninstall Software**

Allows you to uninstall the vehicle-specific Diagnostics, IMMO or T-Darts software.

#### **4.10.8 FAQ**

Allows you to view the frequently asked questions.

#### **4.10.9 Settings**

The Settings function provides general setting options including language setting, unit setting and cache clearing, and allows you to view the version information of the app.

## Section 5

### Specifications

<b>Bluetooth</b>	Version: Bluetooth 5.0 Range: 33 feet (10 m)
<b>Operating System Supported</b>	iOS 11.0 or later Android 7.0 or later
<b>Storage Temperature</b>	-4 °F to 158 °F (-20°C to 70°C)
<b>Working Temperature</b>	14 °F to 122 °F (-10°C to 50°C)
<b>Dimensions</b>	84.1 × 50.4 × 27.2 mm (3.31 × 1.98 × 1.07")
<b>Net Weight</b>	78 g (2.75 oz)



## Section 6

### FAQ

**Q** *What should I do if a communication error occurs?*

**A** Follow the steps below to identify the problem:  
1) Check if the ignition is ON.  
2) Check if the TopScan is securely plugged into the vehicle's OBD-II port.  
3) Turn the ignition off. Then, turn it on after 10 seconds and continue the operation.  
4) Check if the vehicle's control module is defective.

**Q** *Why do I need to download the diagnostic software after installing the TopScan app?*

**A** Since there are various vehicle manufacturers, different diagnostic software is required for different brands.

**Q** *What special functions does the TopScan support?*

**A** The TopScan supports 8 special functions, including Oil Reset, Throttle Adaptation, EPB Reset, ABS Bleeding, Steering Angle Reset, DPF Regeneration, Airbag Reset, and BMS Reset. For the advanced product version - TopScan Pro, there are 5 additional special functions available, including Injector Coding, TPMS Reset, Sunroof Initialization, Seat Calibration, and Window Calibration.

**Q** *Do I need to update the firmware before using it for the first time?*

**A** Yes. Firmware will automatically update to the latest version once the TopScan is connected with your phone via Bluetooth. You can also tap Me > Firmware Update to update the firmware manually.

**Q** *Can multiple devices be bound to one TopScan app account?*

**A** Yes.

# Section 7

## Warranty

### **TOPDON's One Year Limited Warranty**

TOPDON warrants to its original purchaser that the company's products will be free from defects in material and workmanship for 12 months from the date of purchase (Warranty Period).

For the defects reported during the Warranty Period, TOPDON will either repair or replace the defective part or product according to its technical support analysis and confirmation.

TOPDON shall not be liable for any incidental or consequential damages arising from the device's use, misuse, or mounting.

If there is any conflict between the TOPDON warranty policy and local laws, the local laws shall prevail.

This limited warranty is void under the following conditions:

- Misused, disassembled, altered or repaired by unauthorized stores or technicians.
- Careless handling and/or improper operation.

*Notice:*



*All information in this manual is based on the latest information available at the time of publication and no warranty can be made for its accuracy or completeness. TOPDON reserves the right to make changes at any time without notice.*

## Section 8

### FCC

Any changes or modifications not expressly approved by the party responsible for compliance could void the user's authority to operate the equipment. This device complies with Part 15 of the FCC Rules.

Operation is subject to the following two conditions:

- (1) this device may not cause harmful interference, and
- (2) this device must accept any interference received, including interference that may cause undesired operation.

Note: This equipment has been tested and found to comply with the limits for a Class B digital device, pursuant to Part 15 of the FCC Rules. These limits are designed to provide reasonable protection against harmful interference in a residential installation. This equipment generates, uses, and can radiate radio frequency energy, and if not installed and used in accordance with the instructions, may cause harmful interference to radio communications. However, there is no guarantee that interference will not occur in a particular installation. If this equipment does cause harmful interference to radio or television reception, which can be determined by turning the equipment off and on, the user is encouraged to try to correct the interference by one or more of the following measures:

- Reorient or relocate the receiving antenna.
- Increase the separation between the equipment and receiver.
- Connect the equipment into an outlet on a circuit different from that to which the receiver is connected.
- Consult the dealer or an experienced radio/TV technician for help.

Scan the QR code for more support!

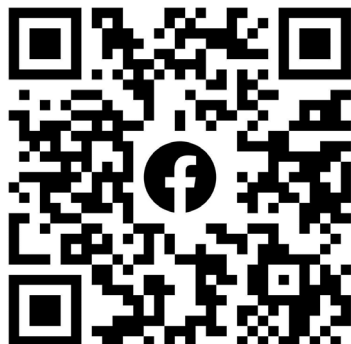



TEL

86-755-21612590  
1-833-629-4832 (NORTH AMERICA)



EMAIL

SUPPORT@TOPDON.COM



WEBSITE

WWW.TOPDON.COM



FACEBOOK

@TOPDONOFFICIAL



TWITTER

@TOPDONOFFICIAL



RoHS



FR

PAPIER

